

### Product Identification

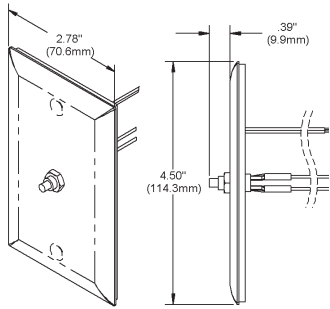

**Figure 1:**  
Wall Plate with Standard Pushbutton Override (O)

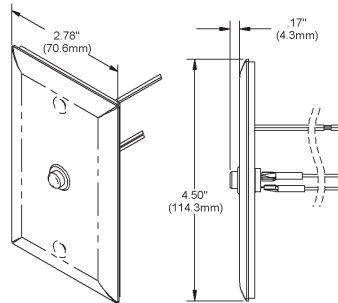

**Figure 2:**  
Wall Plate with Durable Style Pushbutton Override (O1)

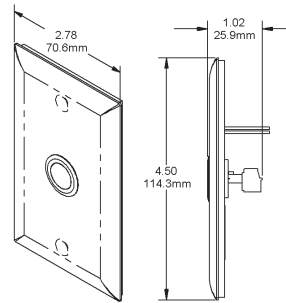

**Figure 3:**  
Wall Plate with Low Profile Style Pushbutton Override (O2)

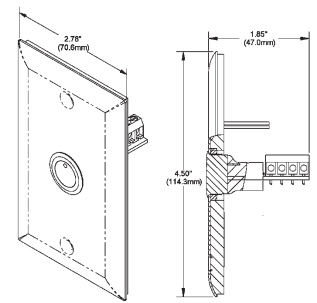

**Figure 4:**  
Wall Plate with Low Profile Style Pushbutton Override (O2G or O2R)

### Mounting

**Ensure the plate does not touch the wall when it is mounted as this will lead to slower response rates when the environment changes.**

Mounting hardware is provided for both junction box and drywall installation.

#### Junction Box

1. Pull the wire through the wall and out of the junction box, leaving about 6" free.
2. Terminate the unit according to the guidelines in **Termination** on page 1.
3. Secure the plate to the box using the #6-32 x 1/2" mounting screws provided or with security screws which are sold separately. (Call BAPI or visit the Accessories section of our website for security screw ordering.)
4. Tighten screws until the foam gasket on the back plate is compressed about 50%. Ensure the plate doesn't touch the wall (Fig 5).

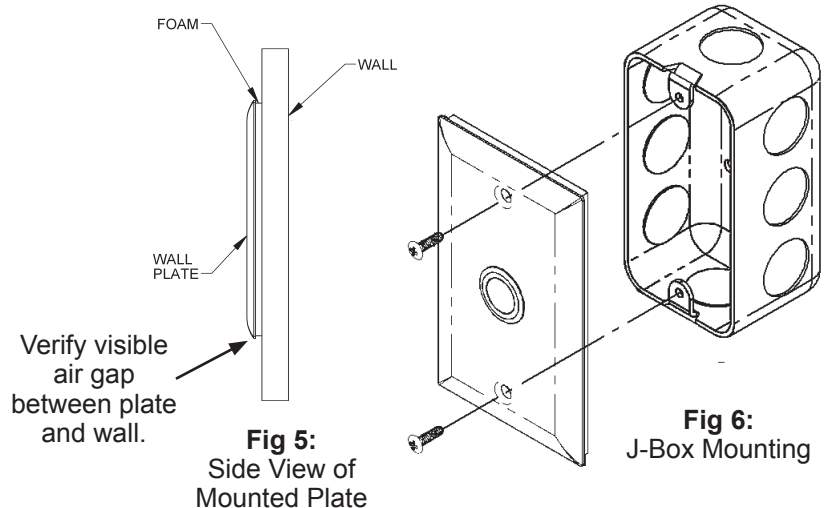

*Note: Louvered wall plates require a mounting adapter bracket for J-Box mounting. The bracket is not shown in the diagram above but is included with any louvered wall plates ordered from BAPI.*

#### Drywall Mounting

1. Place the plate against the wall where you want to mount the sensor and mark out the two mounting holes.
2. Drill two 3/16" holes in the center of each marked mounting hole. Insert a drywall anchor into each hole.
3. Cut hole between the mounting holes that clears the apparatus mounted on plate. Pull the wire through the wall hole cut in step 2, leaving about 6" free.
4. Terminate the unit according to the guidelines in **Termination** on page 1.
5. Secure the plate to the drywall anchors using the #6 x 1" mounting screws provided. Tighten screws until the foam gasket on the back plate is compressed about 50%. Ensure the plate doesn't touch the wall.

**Note:** In any wall-mount application, the wall temperature and the temperature of the air within the wall cavity can cause erroneous readings. The mixing of room air and air from within the wall cavity can lead to condensation, erroneous readings and premature failure of the sensor. To prevent these conditions, seal the conduit leading to the junction box or fill the box with insulation.

Specifications subject to change without notice.

### J-Loop Termination Technique

Incorporating a “J-Loop” (also known as a drip loop) into all terminations adds an additional layer of protection against moisture and oxidation by directing moisture away from the connection. The idea is to place the wire junction as high as possible and form a “J” with the leadwires. The bottom of this “J” should be below the junction point. Any moisture that collects on the leadwires is pulled downward by gravity to the bottom of this loop and away from the junction.

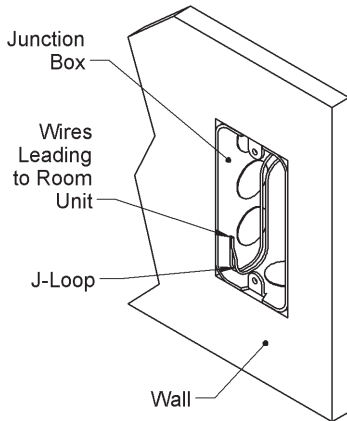

**Fig. 7:** J-Loop Technique

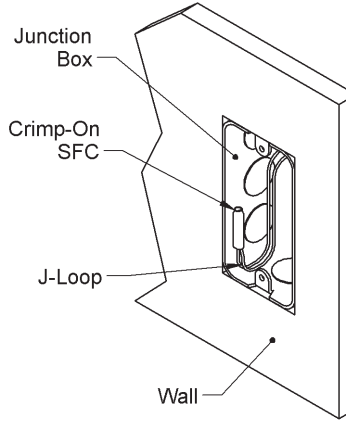

**Fig. 8:** J-Loop with Crimp-On Sealant Filled Connector (BA/SFC1000)

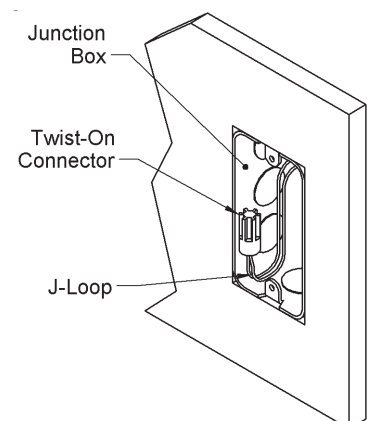

**Fig. 9:** J-Loop with Twist-On Sealant Filled Connector (BA/SFC2000)

### Termination

BAPI recommends using twisted pair of at least 22AWG and sealant filled connectors for all wire connections. Larger gauge wire may be required for long runs. All wiring must comply with the National Electric Code (NEC) and local codes.

Do NOT run this device’s wiring in the same conduit as AC power wiring. BAPI’s tests show that fluctuating and inaccurate signal levels are possible when AC power wiring is present in the same conduit as the signal lines.



BAPI recommends wiring the product with power disconnected. Proper supply voltage, polarity, and wiring connections are important to a successful installation. Not observing these recommendations may damage the product and will void the warranty.

### Sensor Termination:

Terminate the sensor wires to your controller wires using BAPI sealant filled connectors. The wallplate’s foam back insulates the temperature sensor from the wall temperature and/or conduit drafts.

**Table 1: Temperature Sensor Lead Wire Colors**

Thermistors		Thermistors		Platinum RTDs - 2 Wire		Nickel RTD	
1.8KΩ	Orange/Red	10K-3Ω	Yellow/Red	100Ω	Red/Red	1KΩ	Green/Green
2.2KΩ	Brown/White	10K-3(11K)Ω	Yellow/Blue	1KΩ	Orange/Orange	<b>Silicon RTD</b>	
3KΩ	Yellow/Black	20KΩ	White/White	Platinum RTDs - 3 Wire		2KΩ	Brown/Blue
3.25KΩ	Brown/Green	47KΩ	Yellow/Orange	100Ω	Red/Red/Black	Semiconductors	
3.3KΩ	Yellow/Brown	50KΩ	White/Blue	1KΩ	Orange/Orange/Black	LM334	Red/Black
10K-2Ω	Yellow/Yellow	100KΩ	Yellow/White			AD592	Red/Black
						AD592-10K	Red/Black/White

### Termination continued...

The Wall Plate Pushbutton Override is a dry contact, normally-open switch. The contacts close for as long as you hold the switch down. All switches are for NEC Class 2 circuits only.

#### Standard and Durable Override:

The Standard Override (O) and Durable Override (O1) have two white wires attached to either side of the override switch.

#### Low Profile Override:

The Low Profile Override (O2) has three screw terminals that accommodate 16 to 28 gauge wire. The center terminal is not used.

#### Low Profile Override with LED:

The Low Profile Override with LED (O2G or O2R) has four screw terminals that accommodate 16 to 28 gauge wire. The terminals marked OVR are the dry contact output of the override switch, and the + and - terminals are power for the LED.

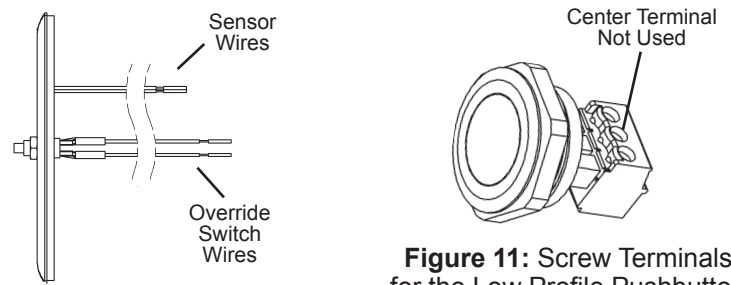

**Fig. 10:** Wiring for the Standard (O) and Durable Pushbutton (O1) Override

**Figure 11:** Screw Terminals for the Low Profile Pushbutton (O2) Override. The center terminal is not used.

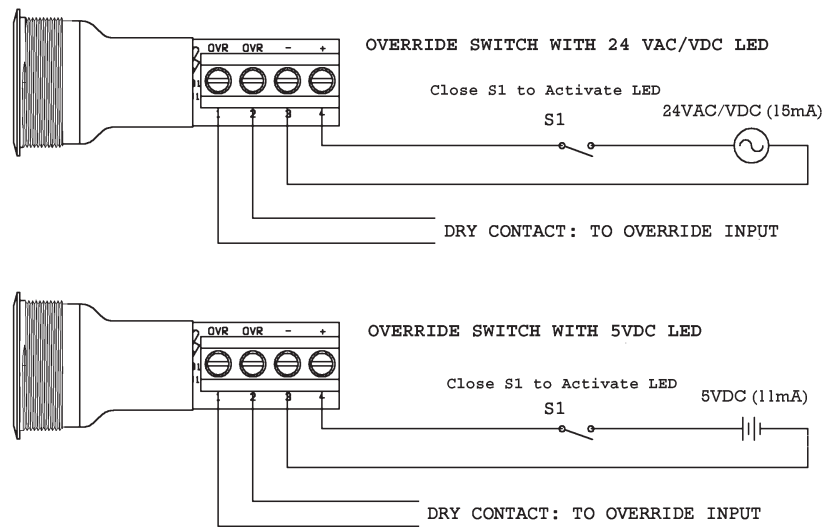

**Fig. 12:** Wiring Examples for a Wall Plate with Low Profile Style Pushbutton Override with 5 VDC and 24 VAC/VDC LED (O2G5 & O2G24 or O2R5 & O2R24)

### Specifications

**Sensor:** Passive

**Thermistor:** Thermal resistor (NTC)

Temp. Output:	Resistance
Accuracy(std):	±0.36°F, (±0.2°C)
Accuracy (High)	±0.18°F, (±0.1°C), [XP] option
Stability:	< 0.036°F/Year, (<0.02°C/Year)
Heat dissipation	2.7 mW/°C
Temp. Drift	<0.02°C per year
Probe range:	-40° to 221°F (-40° to 105°C)

**RTD:** Resistance Temperature Device (PTC)

Platinum (Pt)	100Ω and 1KΩ @0°C, 385 curve,
Platinum (Pt)	1KΩ @0°C, 375 curve
Pt Accuracy (std)	0.12% @Ref, or ±0.55°F, (±0.3°C)
Pt Stability	±0.25°F, (±0.14°C)
Pt Self Heating	0.4 °C/mW @0°C
Pt Probe Range	-40° to 221°F, (-40 to 105°C)
Nickel (Ni)	1000Ω @70°F, JCI curve
Ni Probe Range	-40° to 221°F (-40 to 105°C)

<b>Sensitivity:</b>	Approximate @ 32°F (0°C)
Thermistor:	Non-linear (See bapivac.com for specs)
RTD (Pt)	3.85Ω/°C for 1KΩ RTD
	0.385Ω/°C for 100Ω RTD
Nickel (Ni):	2.95Ω/°F for the JCI RTD
<b>Lead Wire:</b>	22AWG Stranded
<b>Insulation:</b>	Etched Teflon, Plenum rated
<b>Enclosure:</b>	Stainless Steel Plate
<b>Foamback:</b>	0.25" Closed Cell Foam
<b>Mounting:</b>	2x4" J-box or Direct Wall
<b>Ambient (Encl.):</b>	0 to 100% RH, Non-condensing
	-40°F to 185°F, (-40° to 85°C)
<b>Agency:</b>	RoHS, CE, PT = DIN43760,
	IEC Pub 751-1983, JIS C1604-1989
<b>Options:</b>	Override Switch
O	N.O. switch, 115 VAC, 1 amp max
O1	N.O. switch, 28 VDC, 250mA amp max
O2	N.O. switch, 4 to 48 VDC, 150mA max
O2G & O2R	O2 Switch w/ green or red LED, 5V (11mA) or 24V (15mA) power

Specifications subject to change without notice.



# Wall Plate Temperature Sensors with Pushbutton Override (O, O1 & O2 Series)

Installation & Operating Instructions

8587\_ins\_sp\_ap\_o\_01\_02

rev. 08/01/18

## Diagnostics

### Possible Problems:

General troubleshooting

### Possible Solutions:

- Determine that the input is set up correctly in the controller's and building automation software.
- Check wiring for proper termination or corrosion.
- Check for corrosion at either the controller or the sensor. Clean off the corrosion, re-strip the interconnecting wire and reapply the connection. In extreme cases, replace the controller, interconnecting wire and/or sensor.
- Label the terminals that the interconnecting wires are connected to at the sensor end and the controller end. Disconnect the interconnecting wires from the controller and the sensor. With the interconnecting wires separated at both ends measure the resistance from wire-to-wire with a multimeter. The meter should read greater than 10 Meg-ohms, open or OL depending on the meter you have. Short the interconnecting wires together at one end. Go to the other end and measure the resistance from wire-to-wire with a multimeter. The meter should read less than 10 ohms (22 gauge or larger, 250 feet or less). If either test fails, replace the wire.

Temperature reading is incorrect

- Determine that the temperature sensors wires are connected to the correct controller input terminals and are not loose.
- Check the wires at the sensor for proper connections.
- Measure the physical temperature at the temperature sensor's location using an accurate temperature standard. Disconnect the temperature sensor wires and measure the temperature sensor's resistance across the sensor output pins with an ohmmeter. Compare the temperature sensor's resistance to the appropriate temperature sensor table on the BAPI web site. If the measured resistance is different from the temperature table by more than 5% call BAPI technical support. Find BAPI's website at [www.bapihvac.com](http://www.bapihvac.com); click on "Resource Library" and "Sensor Specs", then click on the type of sensor you have. Don't forget to reconnect the wires.
- Make sure that the sensor leads are not touching

Override is not working correctly

- Check that the resistance across the override output is less than 5 ohms when the override switch is pushed

Compare the readings to the appropriate temperature table on the BAPI website:

**<http://www.bapihvac.com>**

Click on "Resource Library" and "Sensor Specs", then on the sensor table needed.

## Related Products

- BA/SFC1000-100** Sealant filled crimp connectors (100 connectors)  
**BA/SFC2000-100** Sealant filled crimp twist on wire nuts (100 nuts)

Specifications subject to change without notice.